

WALTON COMMERCIAL AIR CONDITIONER



Walton Hi-Tech Industries PLC.
(Pioneer of VRF Manufacturing in Bangladesh)

Company Profile

Walton started its business in 1977 and in early 2008 Walton Hi-Tech Industries PLC. started manufacturing Refrigerator, Freezer and Air Conditioner. Now onward Walton is expanding its operation in Television, Home, Electrical & Kitchen Appliances. Walton has become the most trusted and prestigious brand in E&E industry of Bangladesh through its strong manufacturing base, quality products, competitive pricing, extensive market coverage and last but not the least, prompt after sales services. As a result, within a very short period of time, the brand has captured substantial market share and positioned itself as the most dominant performer in the E&E sector of Bangladesh. Product portfolio of WHIPLC. includes Refrigerator (Frost & Non-Frost), Freezer, Air Conditioner, Compressor, Television, Elevator, Home & Kitchen and Electrical Appliances.

Brief History of WALTON GROUP

Beyond Dream

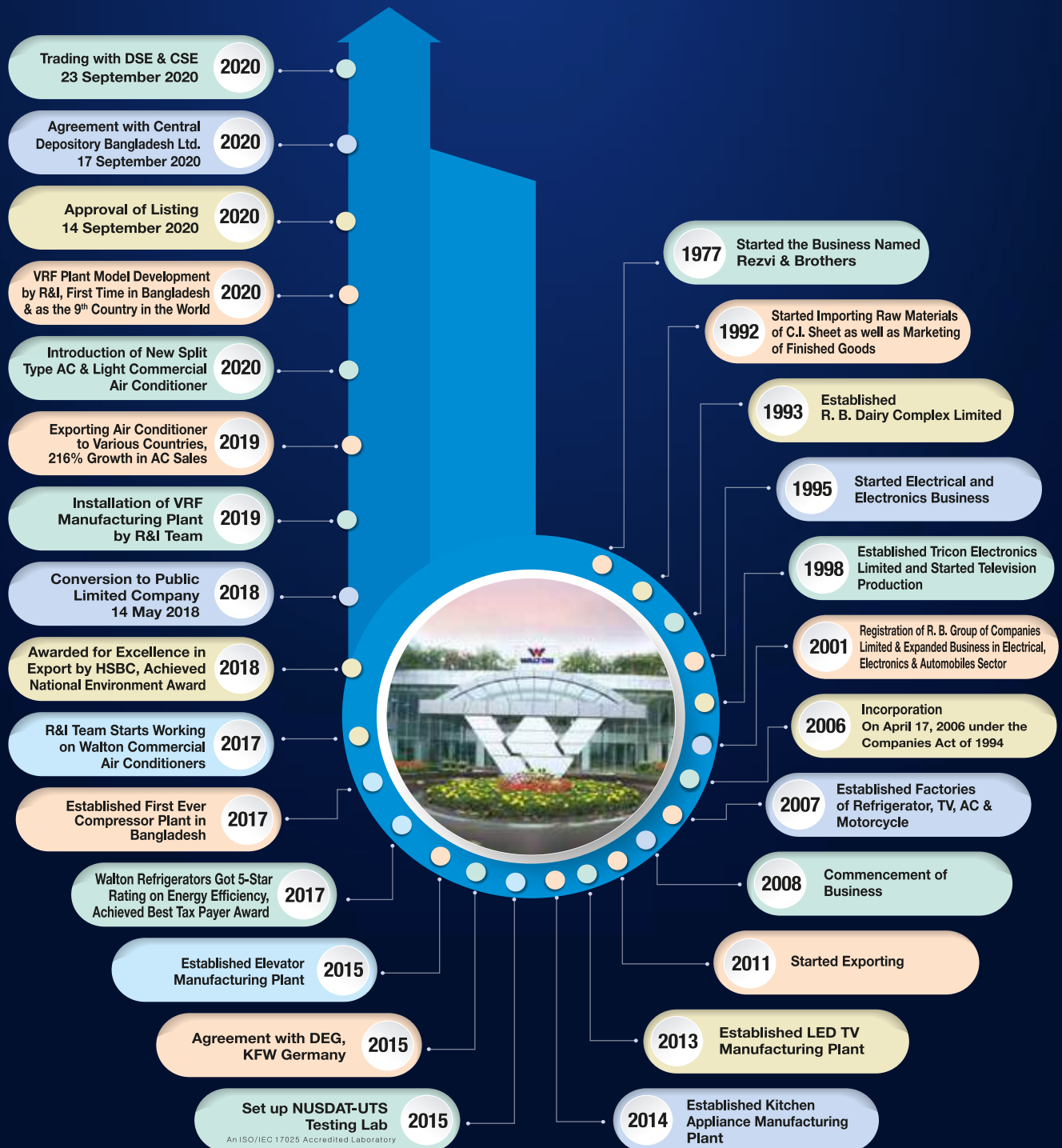

WALTON COMMERCIAL AIR CONDITIONER



VRF
IFM (Intelligent Flexible Module)
Series

Walton IFM Series VRF Air Conditioning System

IFM series always meets the customers' expectation, is committed to technological innovation, focuses on acquisition of users with quality.

Walton proudly introduces its IFM series VRF. IFM series comes with full DC frequency conversion control technology and multi connection with the purpose of energy saving demand of commercial customers. It is considered as the next generation modular system in the world of high efficiency air conditioning system. The new aesthetic design with C-type integrated four sided heat exchanger has undoubtedly changed the face of cooling associated with high storied buildings. With its easy installation and simple controlling system the IFM is designed to meet the demands of the air conditioning industry with its ultra-quiet and purification technology.

Contents

IFM series

Features

Control Technology

Indoor Unit Product Line Up

Indoor Unit Features

Outdoor Unit Product Line Up

Outdoor Unit Features

High Efficiency

9.8 Comprehensive Efficiency (IPLV)

40% ~ 75% Operating Efficiency

IPLV Comparison

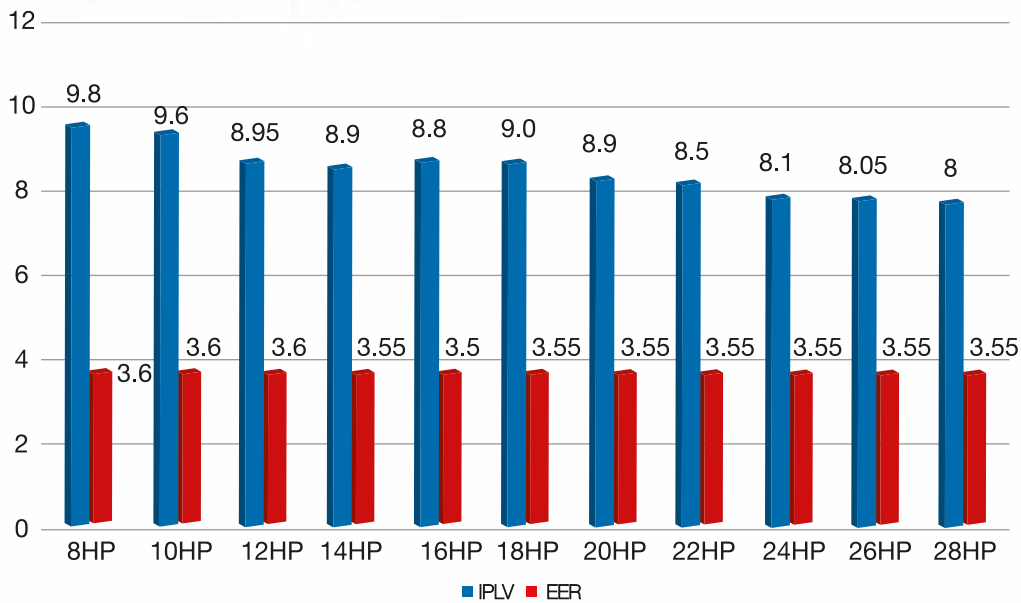

IFM series achieves the industry's top-class energy efficiency in cooling & heating by utilizing DC inverter compressors and Enhanced Vapor Injection (EVI) technology. The Integrated Part Load Value (IPLV) is a performance characteristic developed by the Air-Conditioning, Heating & Refrigeration Institute (AHRI). It is most commonly used to describe the performance of an AC system capable of capacity modulation. Unlike an EER (Energy Efficiency Ratio) or COP (Coefficient of Performance), which describes the efficiency at full load conditions, the IPLV is derived from the equipment efficiency while operating at various capacities. So, IPLV is a very important value to consider since it can affect energy uses and operating costs throughout the lifetime of the equipment.

DC Inverter Fan Motor, More Stable & Energy Saving Operation

- DC Brushless motor adjusts the fan speed according to the system pressure and running load to enhance the efficiency by 45%.
- Super aero fan provides higher static pressure with larger air volume.
- High density winding wire.
- Stepless control and lower noise.

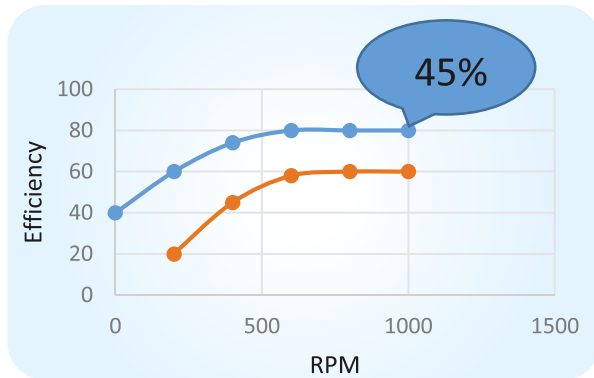

Two Level Depth Subcooling Technology

IFM series adopts the optimized external heat exchanger to realize the first level Sub-cooling and the efficient Brazen Plate Heat Exchanger (BPHE) with super cooling design can reach up to refrigerant temperature 28°C which greatly improves the cycle efficiency.

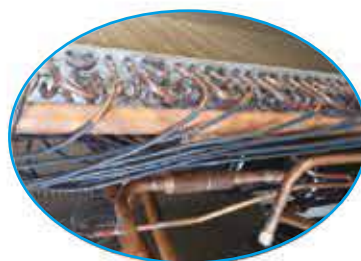
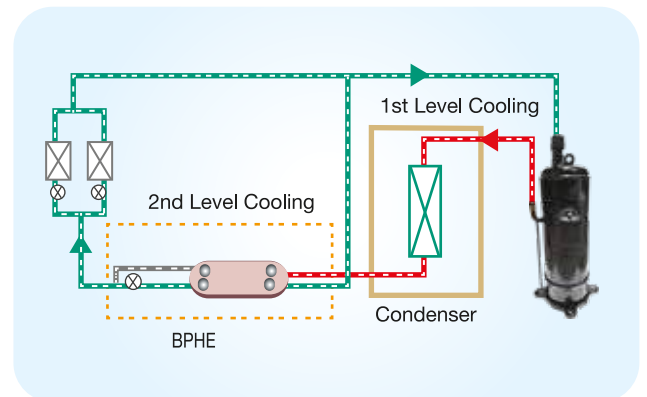

DC Drive Inverter Scroll Compressor with EVI Technology

1. Direct Suction

Reduces superheat & improves volumetric efficiency.

2. Improved Asymmetric Wrap

Additional displacement and superheat reduction for greater compressor efficiency.

3. High Efficiency Motor

Maintains high efficiency levels across with wide range of 10-140 rps.

4. Internal Oil Circulation Structure

Low oil circulation rates (<2%) keep oil in the compressor for superior reliability.

5. Gas Injection Technology

Lowers discharge temperature, increasing capacity & expanded operating envelop for enhanced performance.

6. Bypass Valves

Improved partial load efficiency with self-adapting pressure ratios for upgraded performance of low ambient heating and high ambient cooling.

7. High-Side Pressure Design

Higher volumetric efficiency and improved oil management.

8. Dynamic Oil Balance Structure

Patented technology for unsurpassed oil balance in parallel piped system operation.

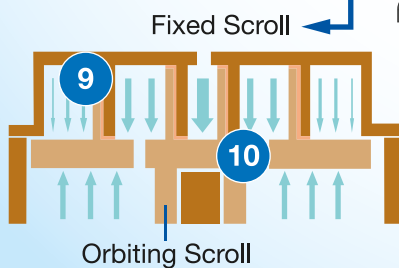
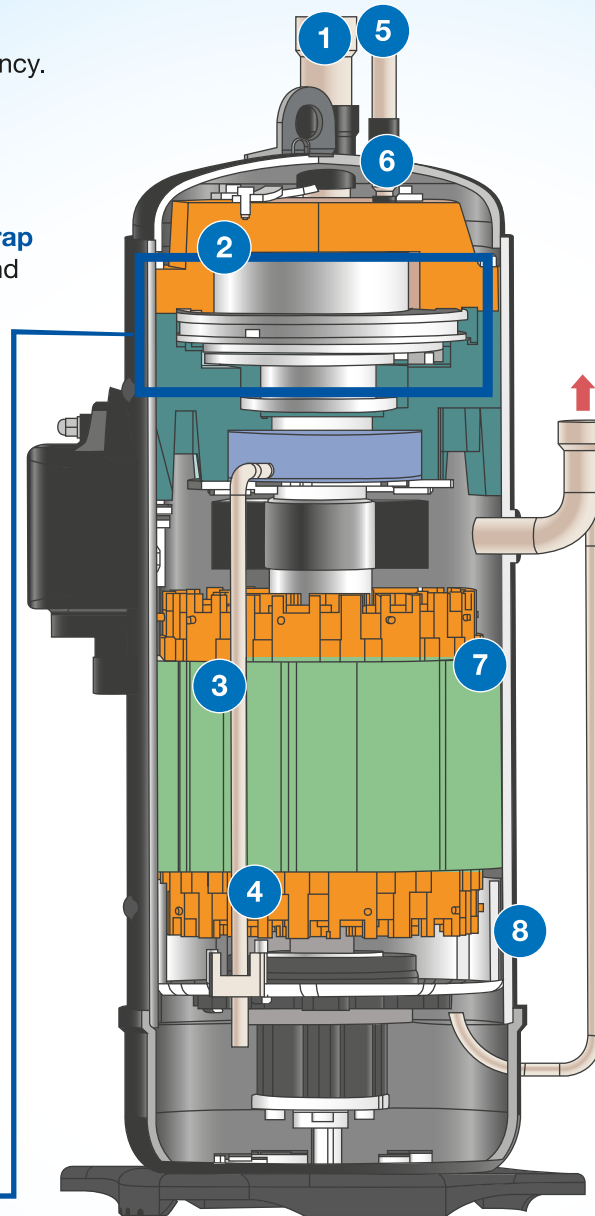

9. Non-contact Oil Membrane

Oil film seals involute section of scroll set, reduces compression leakage for improved performance and lower sound.

10. Intermediate Gas Pressure

Axial force is continually adapting, blending discharge pressure and compressed suction pressure for optimized performance throughout the operating envelop.

Smart Oil Management Technology

Six Level Oil Control

- **Ensure each outdoor unit & compressor is always in the safe oil level to fundamentally solve the safety problem of oil shortage.**

Level 1 : Oil/Mist separation

Level 2 : Efficient oil separator

Level 3 : Balancing oil technology among compressors

Level 4 : Balancing oil technology among outdoors

Level 5 : Gas liquid separator oil return

Level 6 : Automatic oil return of the system

- **Balancing Oil Control Technology**

A balancing oil pipe is set up in the compressor. If oil in the compressor is excessive, the balancing oil & exhaust pipe will work together to send oil to the system which will balance & distribute the oil to the compressor.

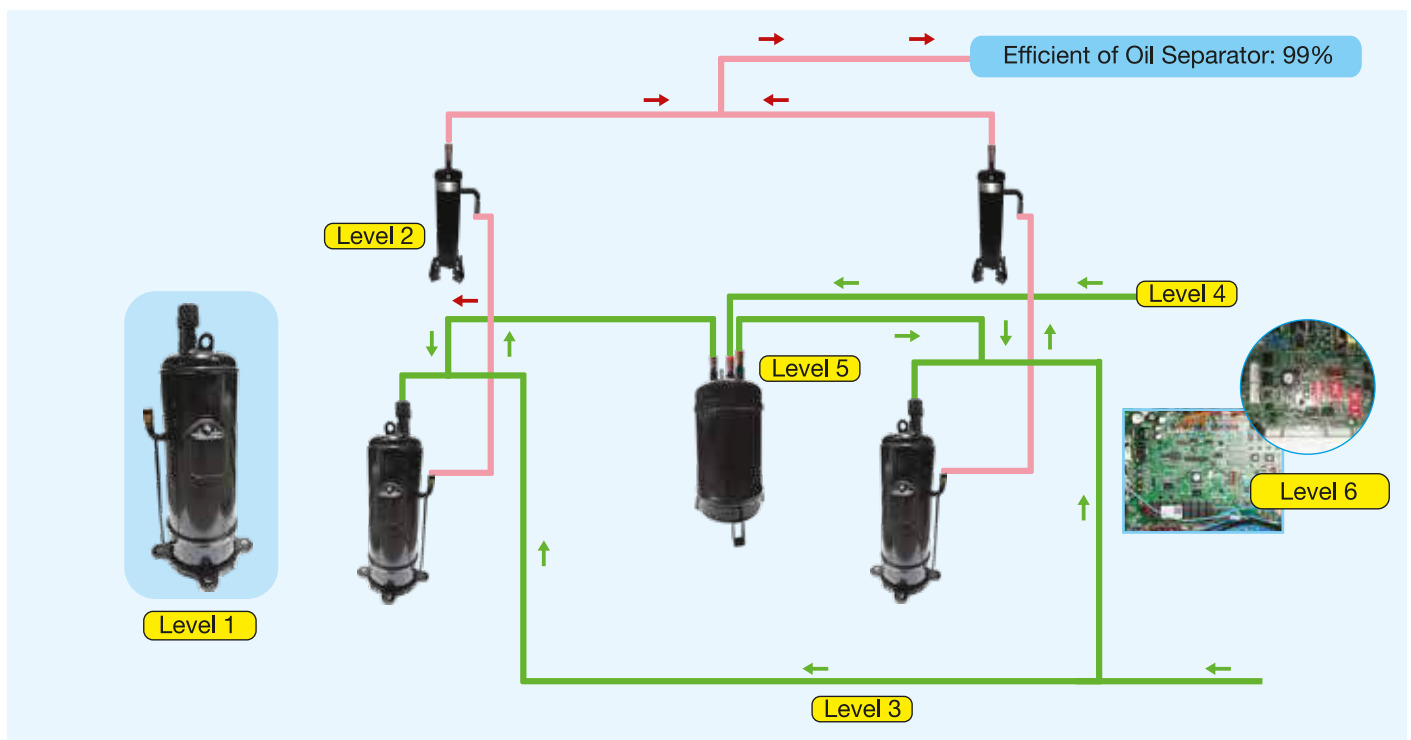

Oil Return Control Technology

- **Oil return in oil separator**

The distinctive structure design – centrifugal oil separator can rapidly separate the oil exhausted from the compressor with oil separation efficiency up to 99% and effectively transmit the oil to various compressors to ensure the oil demand of compressors.

- **Oil return of Gas/Liquid**

Unique oil return hole design can ensure the stable & effective oil return of the compressor. Ultra large capacity design can store more refrigerant for large systems and avoid the liquid strike better.

- **Automatic Oil Return of the System**

The system will automatically return the oil through the instructions issued by the main chip according to the running time & status.

High-Quality Parts & Components : System operates more efficiently

- EEV receives PID control signal to adjust refrigerant volume.
- Continual management of flow rate controls superheat and coil capacity for optimum performance and energy efficiency.
- High precision EEV refrigerant control is more accurate and air conditioning is more stable and comfortable.

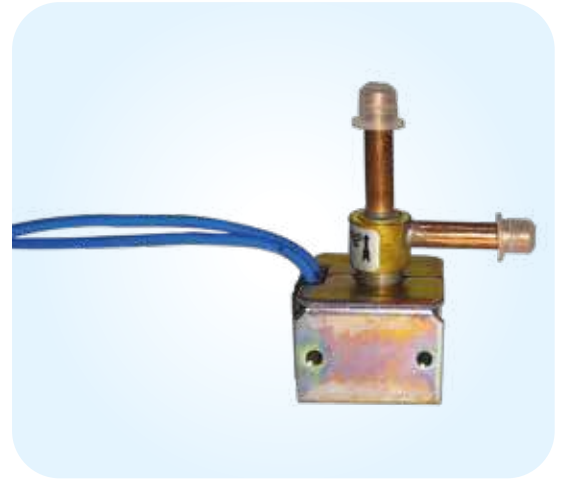

Large Capacity Four-Way Reversing Valve

- Optimal design for four way reversing valve adopts low pressure loss by ensuring the compressor suction volume along with improved to the completeness.



A Variety of Sensing Devices

Fast & accurate detection are the guarantees for the stable and efficient operation of the system. IFM series multi-machine not only detects the unit through temperature sensing but also shows running status through the high pressure & low pressure sensor by accurately detecting the refrigerant condition of the system. As a result, the unit is more stable and runs efficiently.

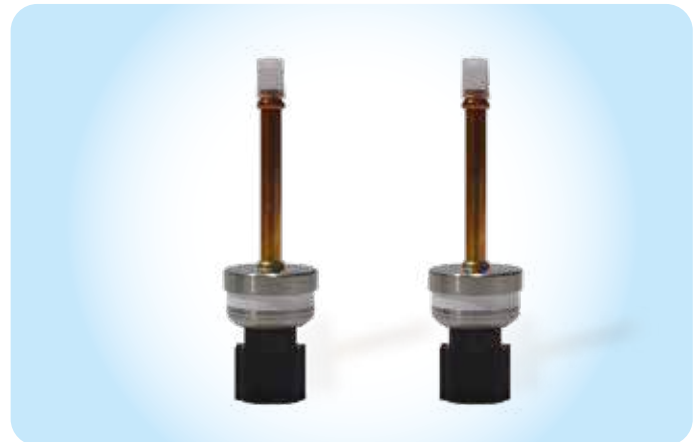

Sensitive Temperature Device

A sensitive temperature sensing device can sense $\pm 0.5^{\circ}\text{C}$. The temperature fluctuates fully to meet the human body's temperature.

SMT

Surface Mounted Technology (SMT) has a low defect rate of solder joints and good reliability. It offers significant advantages during PCB manufacture and in the matter of size with the use of SMT components enable far more electronics to be packed into a much smaller space. In addition to the size, Surface Mounted Technology allows automated PCB assembly and soldering to be used and this brings significant improvements in reliability as well as enormous savings in cost.

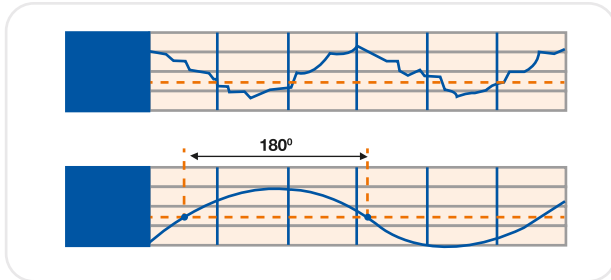

Advanced 180° Vector Frequency Conversion Technology

In the DC frequency conversion controller's output is smooth 180-degree positive sign pool shape. The stator coil of the compressor always forms a stable traveling magnetic field from low speed to high speed, effectively reduces the copper pressing along with sound.

Stepless Frequency Conversion Technology

The unit can be adjusted from (10~100)% stepless capacity with continuous speed of the running compressor, free adjustment according to the changes of the system capacity and automatic capacity adjustment to meet the actual load.

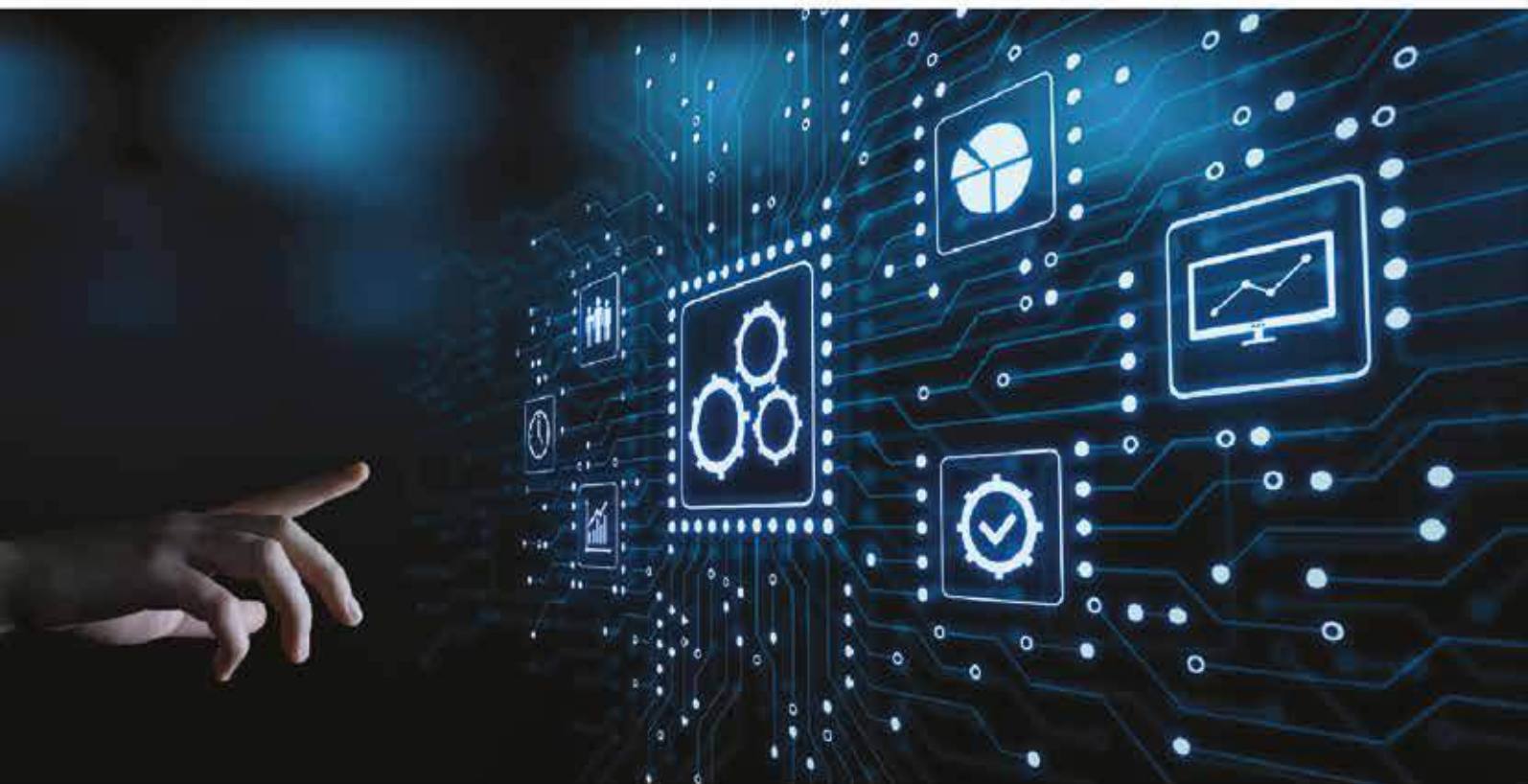

Load Sharing Operation Ensuring Long-life and Reliability

Rotation Technology

Through the rotation technology, the running time of each outdoor unit is shared to ensure longer service life and durability for each system.

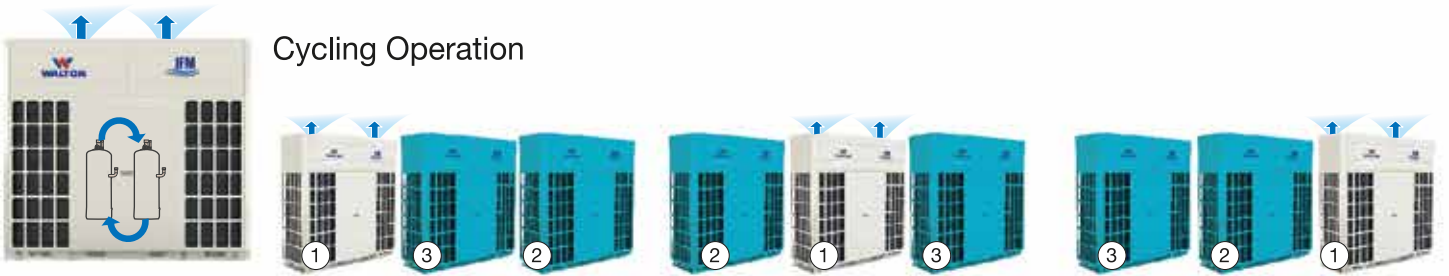

Dual Backup Operation

The outdoor unit has dual emergency functions. As for the first backup, if one of the two compressors in the outdoor unit fails (12HP or more), the other compressor can run in emergency. As for the second backup, if one outdoor unit in a system of more than 24HP fails then the alternative outdoor unit can operate in emergency mode.

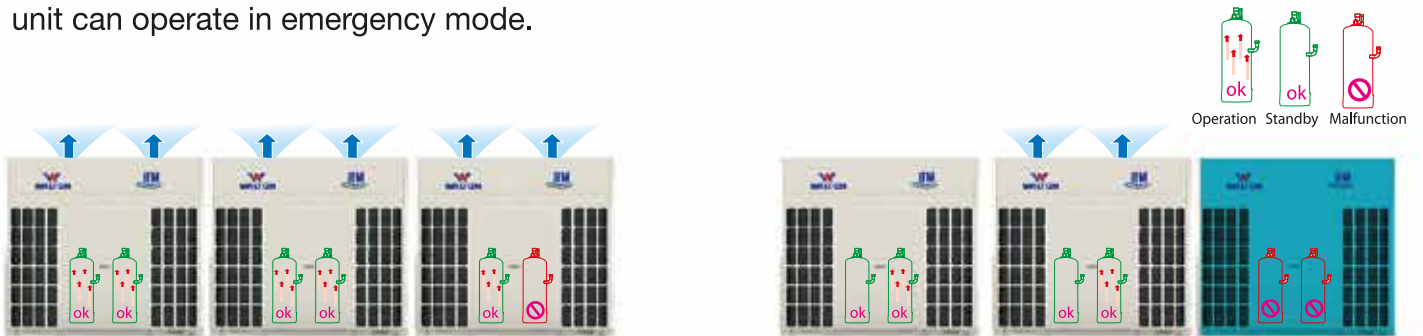

Smart Defrosting Technology

When a building uses a VRF system during winter, frost accumulation on the outdoor unit can hinder performance. The unit's heating capacity is gradually reduced as ice builds up on the outdoor coils and excessive frosting can damage the system. To address this issue, manufacturers use a defrost cycle that reverses the heat pump's operation:

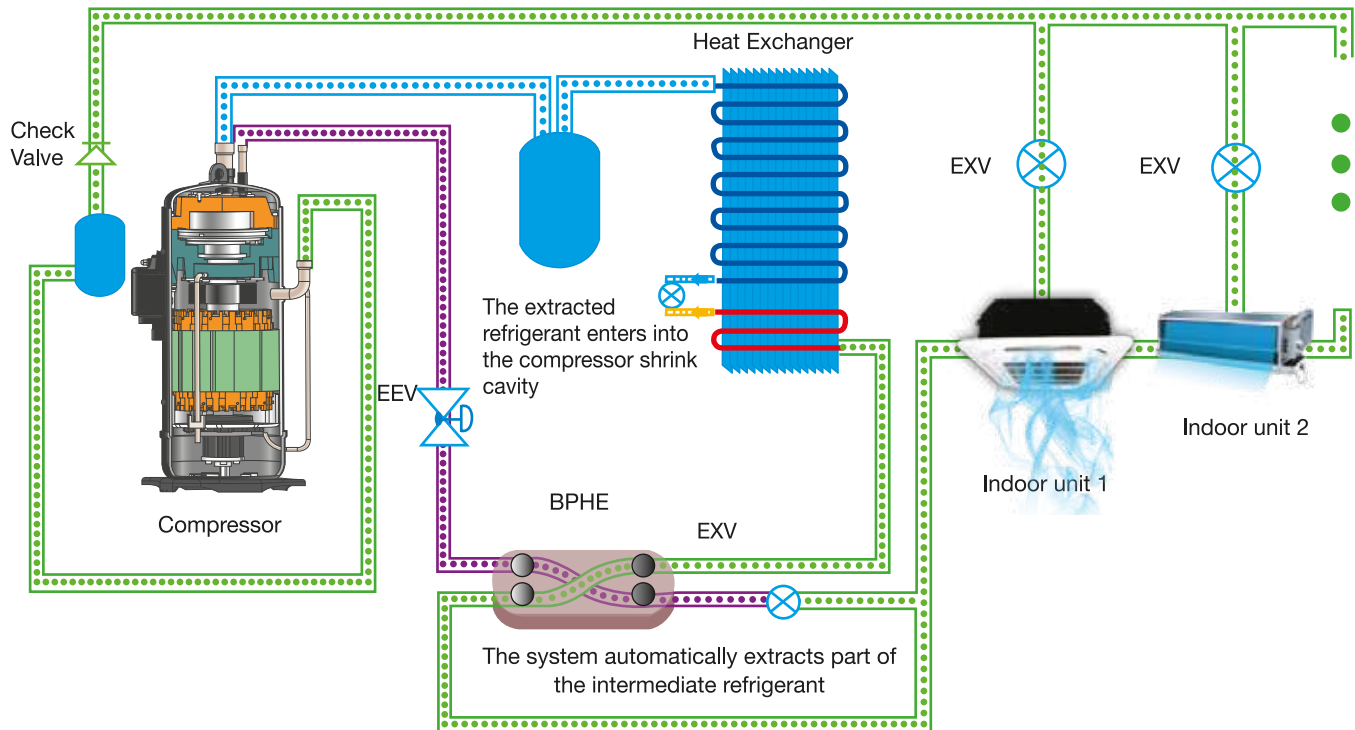

- Frost builds up on a heat exchanger in an outdoor unit if outdoor temperature is low & humidity is high.
- Frost can decrease heating performance. Automatic defrosting will start to remove frost. Heating will pause for 5-7 minutes.
- Vapor can be generated from the outdoor unit during defrosting is a normal sign of throwing.
- A heat pump in defrost mode operates similarly to an air conditioner, draws heat from indoor air and releases it outside.
- The released heat melts the accumulated ice on the outdoor coil.
- When the outdoor unit is defrosted, the heat pump returns to heating mode.

Water pulling under the outdoor unit as frost melts IFM series ensures water drainage properly.



High Efficiency Heat Exchange

The outdoor heat exchanger adopts the high efficiency internal grooved copper tube and new hydrophilic aluminum fin. Its integral molding technology guarantees the larger heat exchange area, improves the airflow distribution, reduces the airflow resistance, exchanges the heat more efficiently and reduces the impact of the frosting on the heating capacity of the system.



Blue Fin



Black Fin



Golden Fin

Refrigerant PCB Cooling Technology

During outdoor machine operation, the inverter produces a lot of heat. If the frequency of temperature is too high, it will lead the motherboard overheating which affects the system's stability. New generation inverter cooling technology is using low temperature cold media cooling motherboard, air cooling to take away a lot of heat distributed by the motherboard is guaranteed to keep the system more stable.

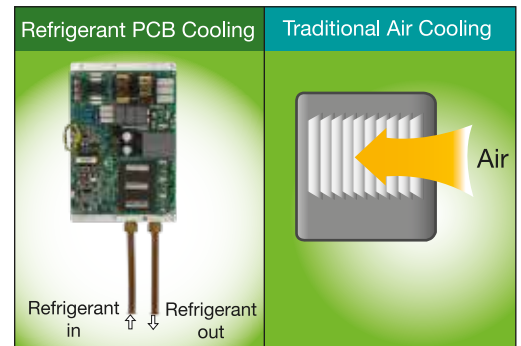

Refrigerant Control Technology

The structural integration of solenoid valve & capillary tube ensure a relatively uniform distribution of the refrigerant & reasonable and effective utilization of heat exchanger. The solenoid valve performs the ON/OFF actions to disconnect the refrigerant flow path so that it can effectively control the heat exchanging temperature of indoor unit.

Ultra Wide Range of Operation

New DC inverter scroll compressor is used & its heating operating temperature range is -25~28°C (Cooling -15~53°C).

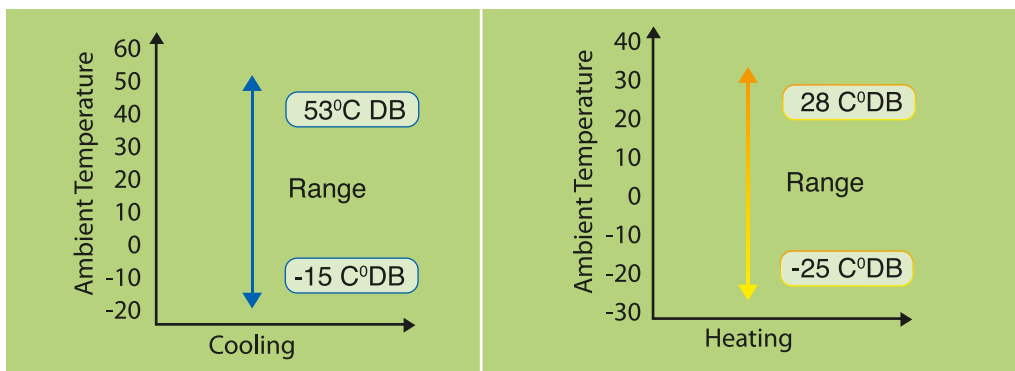

Pressure Control Technology

The direct contact of pressure sensor & refrigerant in the pipeline can timely & accurately test the running high & low pressure of the system and quickly carry out the control & protection of the air conditioning system according to the system load & need. It tests the low/high pressure of the system and adjust the rotating speed of the external fan accurately and adjust the refrigerant in combination with the electronic expansion valve meanwhile control the output adjustment of the external capacity in variable capacity system to ensure the efficiency of the system which ensures the system more reliable.

Automatic Dust Removal Function

- Reverse running technology of DC fan automatically cleans the heat exchanger's inside equipment.
- After cleaning, it improves efficiency of the heat exchanger.
- Improves the cleanliness of the heat exchanger and extends the product life.



Normal Operation



Self Cleaning Operation



Super Long Connecting Pipe, Free and Flexible Design & Construction

Long Piping Length

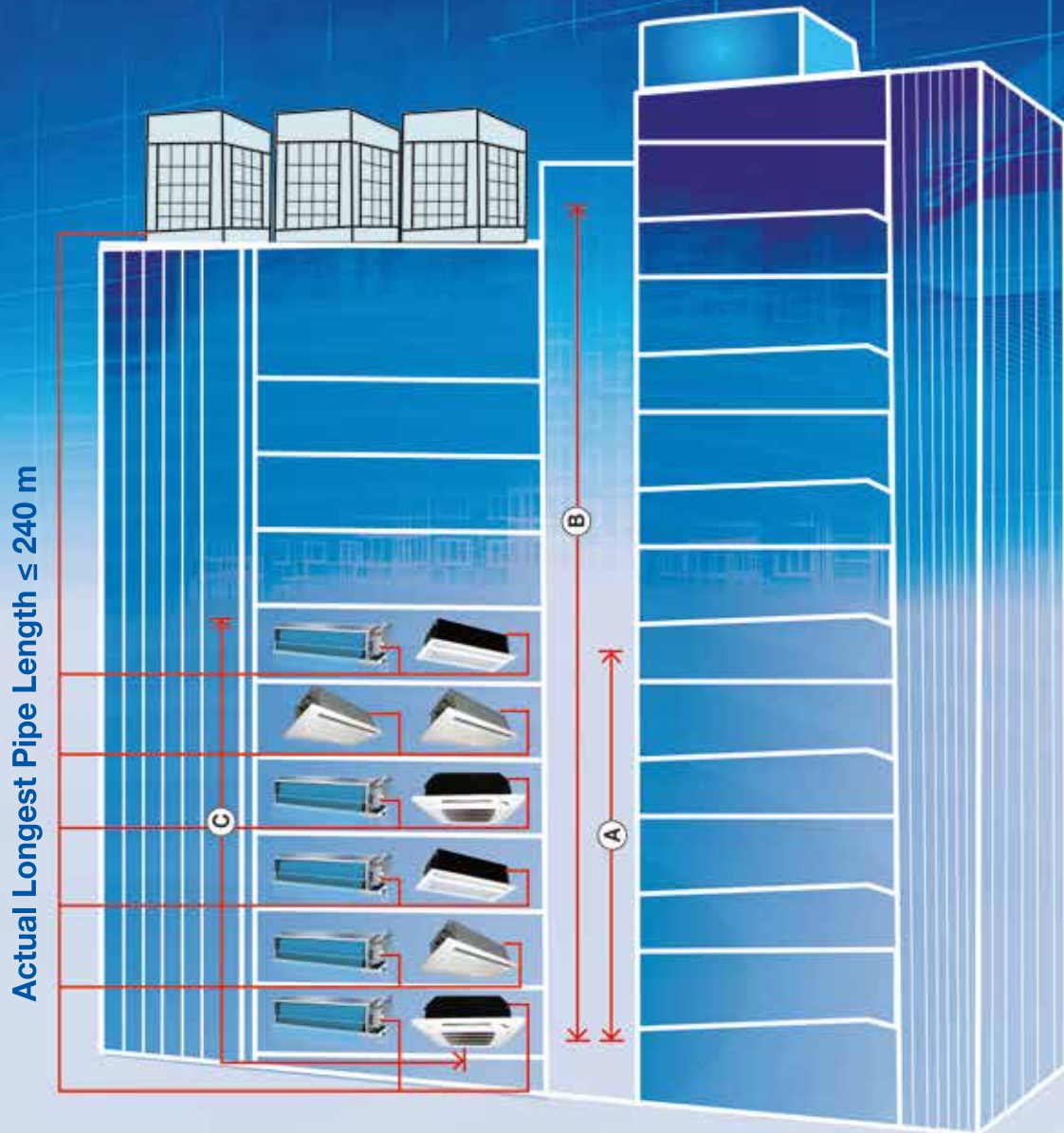

Maximum Total Piping Length ≤ 1000 m

- A. Maximum height between IDU-IDU ≤ 30 m
- B. Maximum height between ODU-IDU ≤ 110 m
- C. Longest pipe length after first branch ≤ 90 m

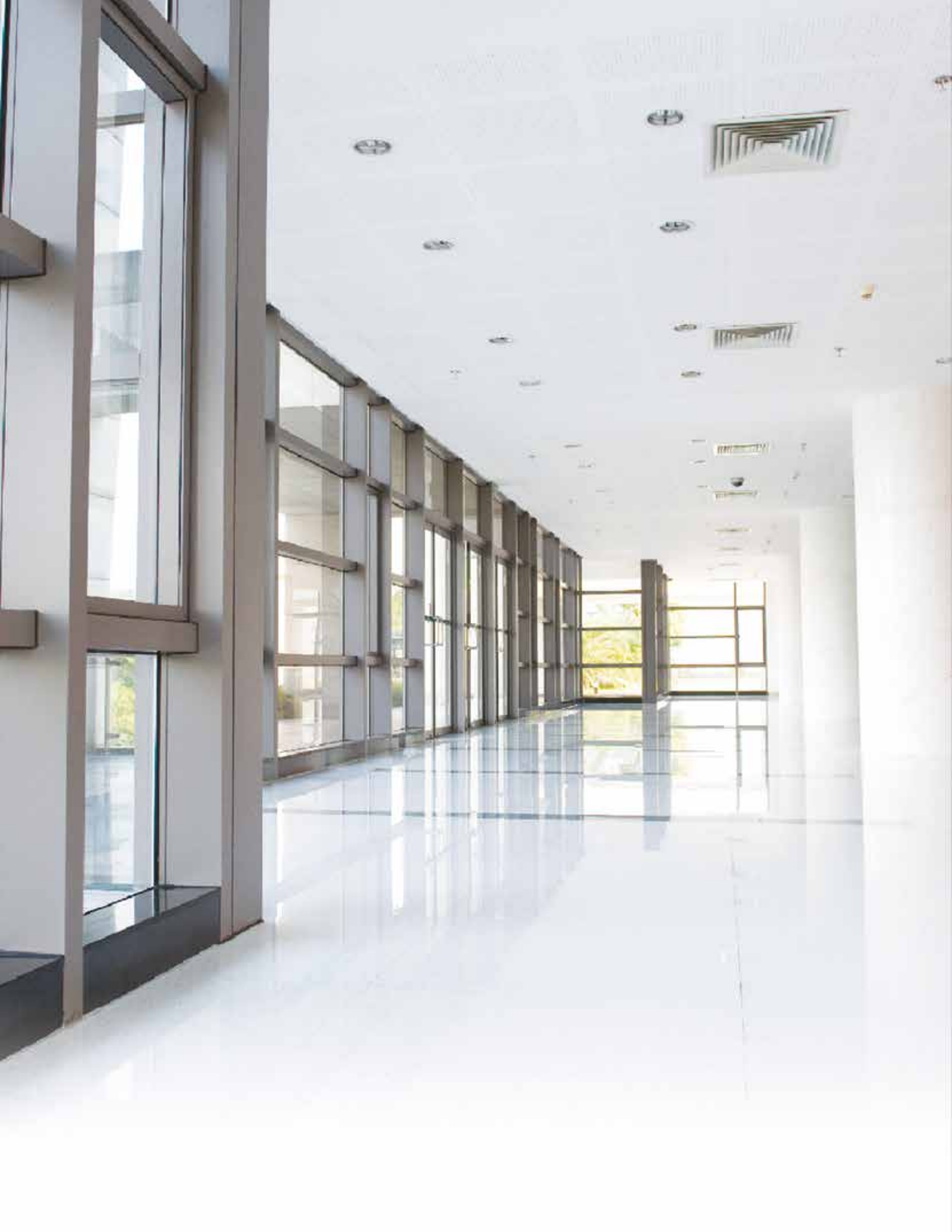

A variety of controllers to meet individual needs

Standard Wired Controller

- Mode adjustment / fan speed / temperature / humidity adjustment
- Schedule management
- Fault display / filter cleaning reminder
- Built in wireless remote controller receiver
- Built in temperature sensor
- Physical button, enjoy the pleasure on fingertips

WRC100



Wireless Remote Controller

- Mode adjustment / fan speed / temperature / humidity adjustment
- Schedule management
- Air deflector control
- One key mute
- One key energy saving

WRC200



Wire Touch Screen Remote Controller

- Mode adjustment / fan speed/temperature / humidity adjustment
- Schedule management
- Fault display / filter cleaning reminder
- Built in wireless remote controller receiver
- Built in temperature sensor
- Smart human sensor for interactive wake up function
- One key group shutdown

WRC300



Note: Remote control line controller.

Monitoring Software

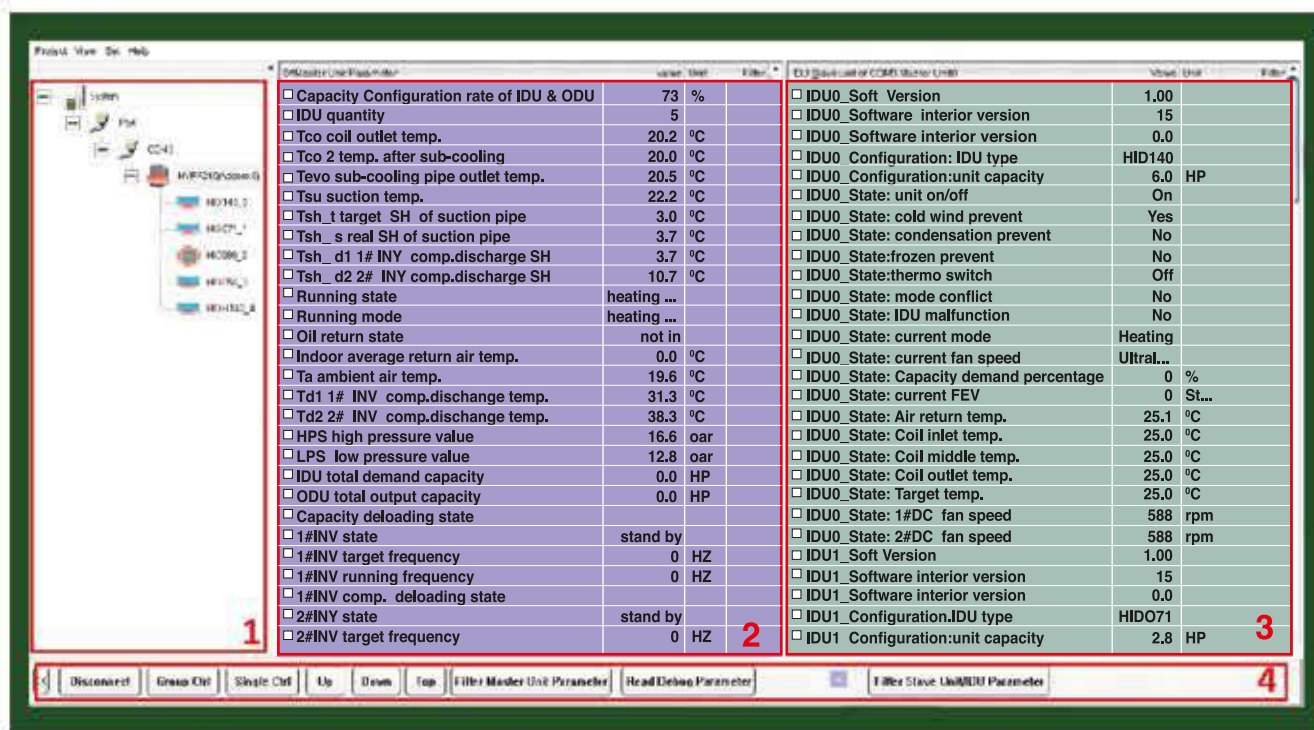

1. Connected Unit

2. Master/Outdoor Unit Parameter

3. Slave/Indoor Units Parameter

4. Toolbar

Monitoring Software System Connection.

Main Components (Requirements & Function)



Connection with Outdoor Control PCB Communication Port



RS485 to USB Converter



Connect with PC



Indoor Group Control



Indoor Individual Control

Building Automation System

IFM series frequency conversion multilink can provide users a variety of building control system. Building automation system is based on ModBus communication protocol, controller can be directly connected through standard ModBus communication port, no frequency conversion is needed for the units. Controller can be connected with building automation system.

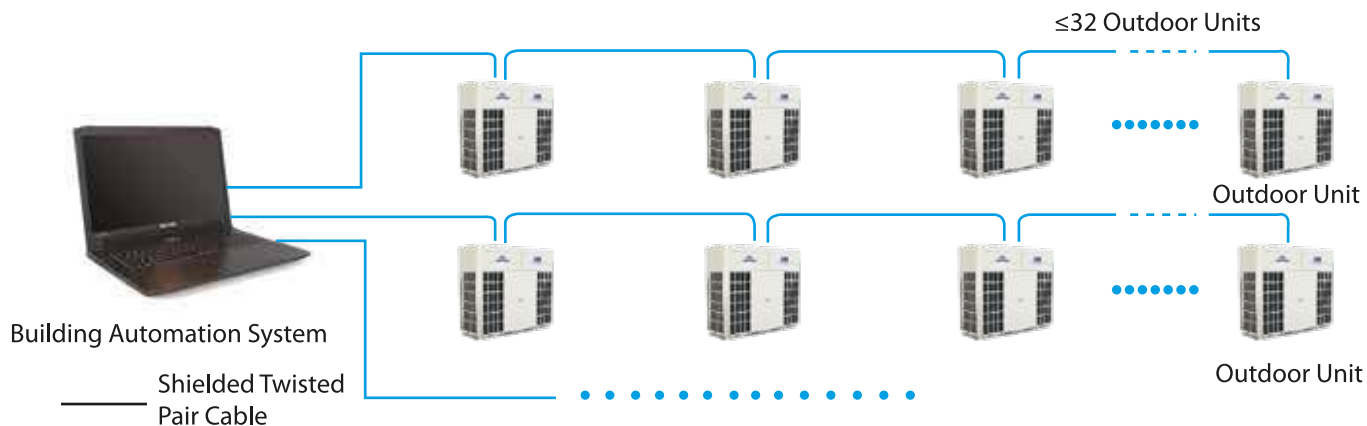

For building automation system based on BACnet, controller is connected through BACnet gateway protocol. In BACnet protocol, not more than 24 outdoor units can be connected, total number of machine does not exceed 1536.

Main Features:

- Air Conditioner switching and monitoring
- Lower controller permission settings
- Monitor and set fan operation
- Monitoring and switching operation modes
- Monitor and set indoor unit temperature

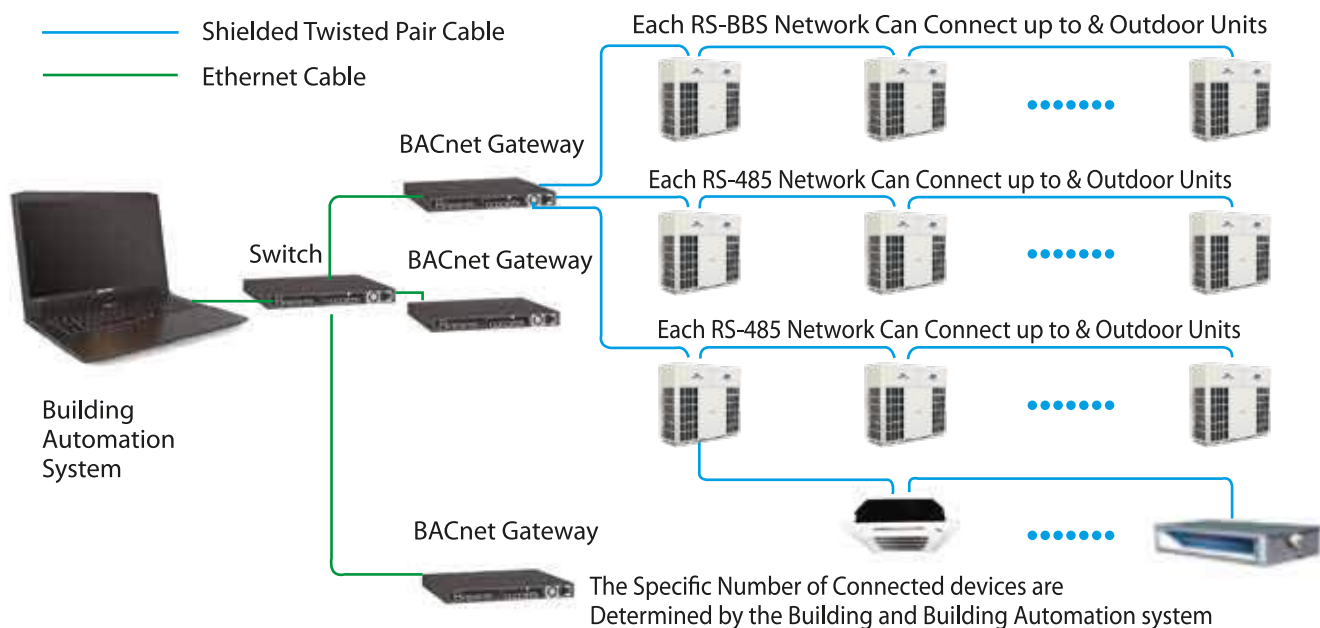

Intelligent Monitoring and Billing System

Intelligent Monitoring System W-CCS101A

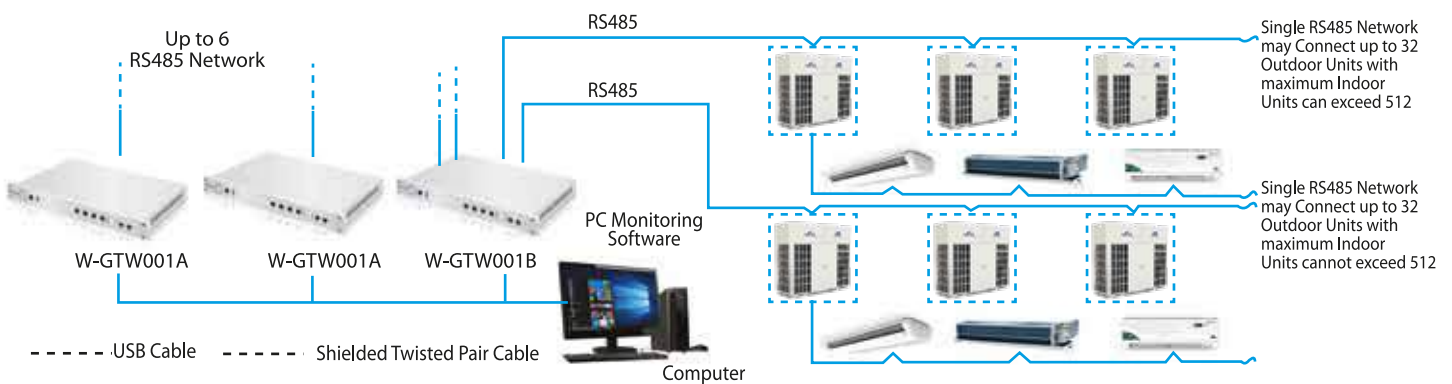

Main Features:







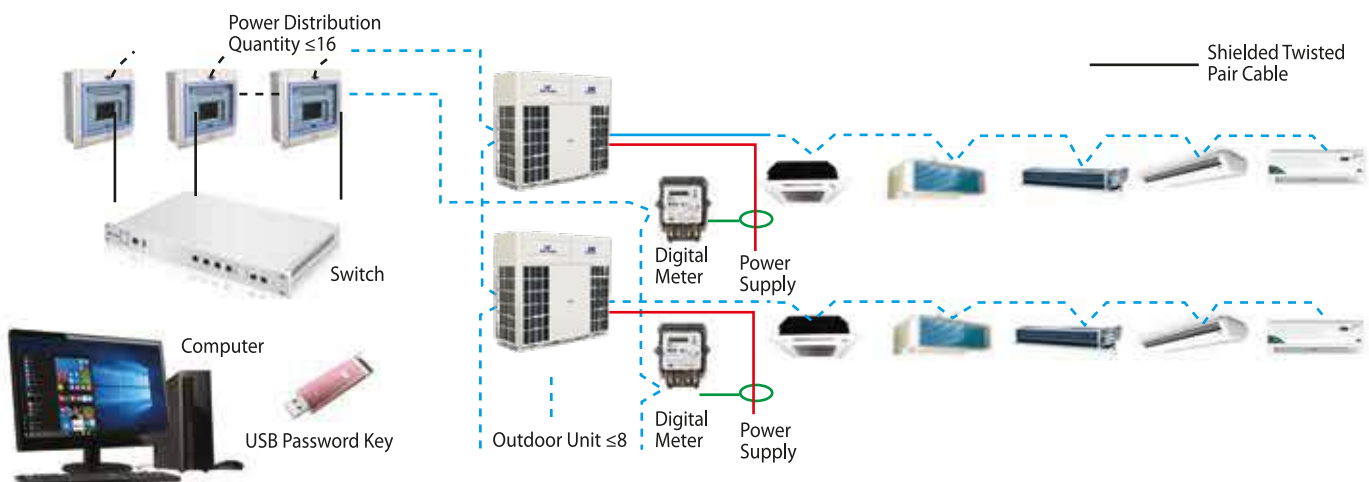



- Monitoring System: With device view and user monitoring, it is convenient for real-time monitoring of internal machines.
- Switching Machine & Mode Control: Mode, Fan Speed, Zone Temperature, Switch Machine can be performed on all units in the system and auxiliary functions for operating settings.
- Locking Function: The local thermostat can be locked.
- Group Management: Group settings can be customized to facilitate the management of different regions.
- Schedule Management: Timing commands, each indoor unit may start and stop regularly.
- System Management: Indoor unit operation meter, Indoor and Outdoor unit operation and fault records, output operation report.

Household Billing System W-CCS102A

Intelligent household billing software system is designed and developed for air condition system to manage individual unit which can be connected with up to 128 outdoor units. All the Indoor units are connected to it to carry out the system based billing, the power calculation is more reasonable and the management is easier.



Indoor Unit Product Lineup

Indoor Unit Capacity Range																						
Indoor Type	Capacity Range (KW)	1.8	2.2	2.5	2.8	3.2	3.6	4.0	4.5	5.0	5.6	6.3	7.1	8.0	9.0	10.0	11.2	12.5	14.0	16.0	22.4	28.0
Ducted (Low Static Pressure)			•	•	•	•	•	•	•	•	•	•	•									
Ducted (Medium Static Pressure)		•	•	•	•	•	•	•	•	•	•	•	•	•	•	•	•	•	•	•		
Ducted (High Static Pressure)																•	•	•	•		•	•
Two-way Cassette								•		•	•	•	•	•								
One-way Cassette							•			•		•										
Four-way Cassette					•	•	•	•	•	•	•	•	•	•	•	•	•	•	•	•		
Compact Four-way Cassette					•	•	•	•	•	•	•	•	•	•	•	•	•	•	•	•		
Outdoor Air Processor													•	•	•	•	•	•	•	•	•	•
Wall Mounted			•		•		•		•		•		•									
Ceiling									•		•		•				•		•	•		

Indoor Units Nomenclature

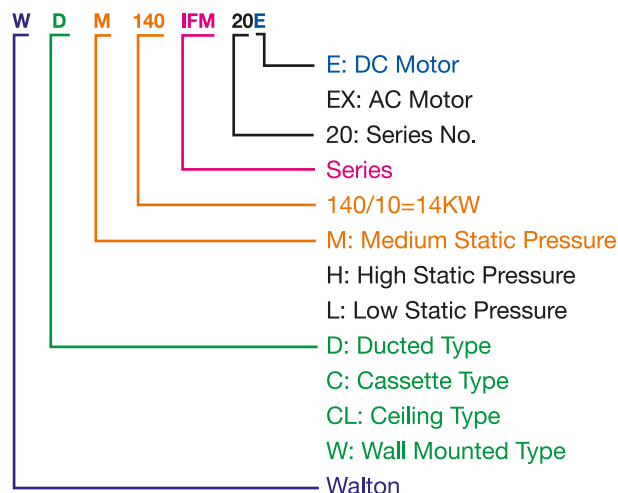

Four Way Cassette



Built-in water drainage pump up to 1200 mm head

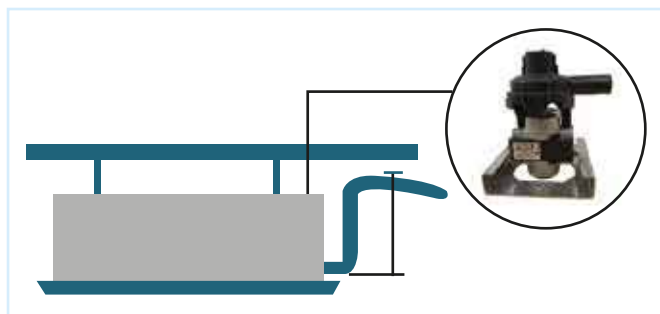

Inverter DC fan motor

Power consumption is greatly reduced, especially when running at low speed, the operating efficiency is greatly improved.

- Improve the ceiling space experience
- Controllable tube position to avoid beam interruption
- Risk-free of bubble forming
- Avoid the accumulation of condensate in the water tray that prevents breeding bacteria.



Ultra Slim Design

Only 250 mm height saves installation space.

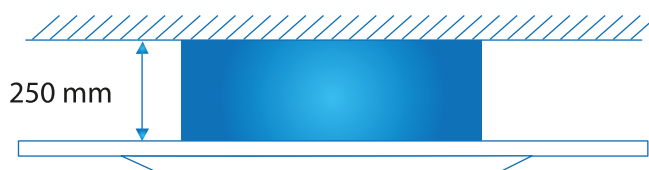

Specifications

Model		WCM561FM20EX	WCM711FM20EX	WCM901FM20EX	WCM1401FM20EX
Nominal Cooling Capacity	W	5600	7100	9000	14000
Nominal Heating Capacity	W	6300	8000	10000	16000
Rated Input Power	W	75	99	180	200
Rated Input Current	A	0.33	0.43	0.83	0.9
Sound Pressure Level (High, Medium and Low)	dB (A)	49/45/39	49/45/40	50/46/40	50/46/40
Air Volume (High, Medium and Low)	CMH	990/680/570	1000/830/690	1900/1700/1600	2000/1900/1800
Liquid Pipe Connection Size	mm (in)	Ø6.35 (1/4")	Ø9.52 (3/8")	Ø9.52 (3/8")	Ø9.52 (3/8")
Gas Pipe Connection Size	mm (in)	Ø12.7 (1/2")	Ø15.88 (5/8")	Ø15.88 (5/8")	Ø15.88 (5/8")
Condensate Water Pipe Size	mm	Ø20.5	Ø20.5	Ø20.5	Ø20.5
Unit Size (W x D x H)	mm	840 x 835 x 240	840 x 835 x 240	840 x 840 x 310	840 x 840 x 310
Unit Weight	kg	28	28	39	39
Power Supply		230V~/50Hz	230V~/50Hz	230V~/50Hz	230V~/50Hz

Duct Series

**Low ESP
Duct**



**MID ESP
Duct**



**High ESP
Duct**



PM 2.5 Solution : Efficient Removal Module

With indoor engine optional PM 2.5 filtering, three nets and the highest removal rate of 99% are to achieve indoor air circulation with healthy indoor environment.



Better World For Future

Fine particulate matter (PM 2.5) is an air pollutant that is a concern for people's health when levels in air are high. PM2.5 are tiny particles in the air that reduce visibility and cause the air to appear hazy when levels are elevated. Outdoor PM levels are most likely to be elevated on days with little or no wind or air mixing. IFM series ensures the purification rate of 2.5 is over 99% within 2 hours.

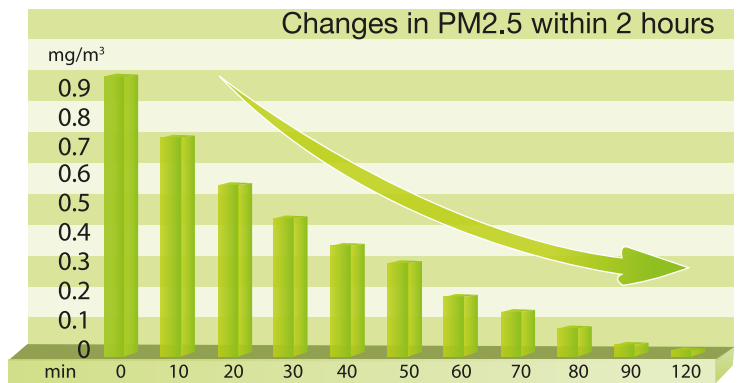

Continuous Formaldehyde Solution

The indoor unit is equipped with formaldehyde filtration, effectively decomposing harmful formaldehyde molecules in the air.



Continuous Removal

High efficiency absorption formaldehyde function removes allergens & bacteria. The removal rate is 90%.



Strong Decomposition

Quickly captures the formaldehyde, the coincide with the catalyst decomposes formaldehyde as water and dioxide.



Simple Installation

Formaldehyde filter assemblies are simple and convenient.

Mid ESP Duct Flexible Air Intake Option

Air intake from rear is standard but from bottom is optional. The size of the plate from bottom is the same as the flange from back which makes it convenient to change installation style according to requirements.

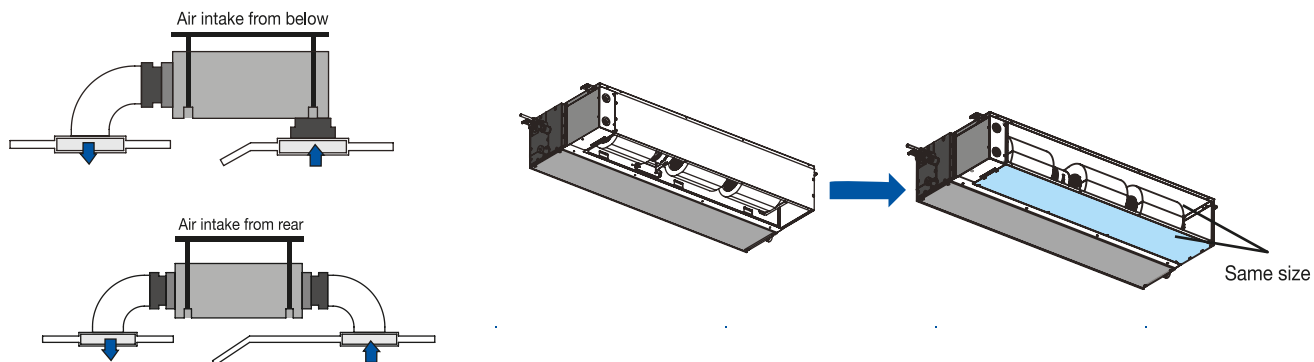

Ducted Type – Medium Static Pressure

Model		WDM56IFM20E	WDM71IFM20E	WDM90IFM20E	WDM140IFM20E
Nominal Cooling Capacity	W	5600	7100	9000	14000
Nominal Heating Capacity	W	6300	8000	10000	16000
Rated Input Power	W	49	59	98	169
Rated Input Current	A	0.33	0.52	0.83	1.36
External Static Pressure	Pa	10 (0/30/50)	10 (0/30/50)	50 (30/80/100)	50 (30/80/100)
Sound Pressure Level (High, Medium and Low)	dB (A)	33/30/28	34/31/29	36/34/33	38/37/35
Air Volume (High, Medium and Low)	CMH	800/680/570	1000/830/690	1400/1200/980	2200/1830/1520
Liquid Pipe Connection Size	mm (in)	Ø6.35 (1/4")	Ø9.52 (3/8")	Ø9.52 (3/8")	Ø9.52 (3/8")
Gas Pipe Connection Size	mm (in)	Ø12.7 (1/2")	Ø15.88 (5/8")	Ø15.88 (5/8")	Ø15.88 (5/8")
Condensate Water Pipe Size	mm	Ø20.5	Ø20.5	Ø20.5	Ø20.5
Unit Size (W x D x H)	mm	900 x 450 x 210	1150 x 450 x 210	1150 x 600 x 300	1450 x 600 x 300
Unit Weight	kg	19.8	23	40.5	42
Power Supply		220V~/50Hz	220V~/50Hz	220V~/50Hz	220V~/50Hz

Notes:

- Cooling Capacity:** Indoor temperature 27°C DB/19°C WB; Outdoor temperature: 35°C DB/ 24°C WB.
- Heating Capacity:** Indoor temperature 20°C DB; Outdoor temperature: 7°C DB/ 6°C WB.
- We can guarantee the operation only within 130% combination. If you want to connect more than 130% combination, please contact us and discuss the requirement.
- Anechoic chamber conversion value, measured in test room. During actual operation these values are somewhat higher as a result of ambient condition.
- The above designs and specifications are subject to change without prior notice. For final specifications please refer to technical specification provided by sales representative.
- Sound values are measured in a semi-anechoic room, at a position 1m in front of the unit and 1.3m above the floor.
- Choosing fuse or breaker according to MFA and electrical wiring according to MCA.
- The above data may be changed without notice for future improvement in quality and performance.

High ESP Duct :

Applicable to a Variety of Rooms

High ESP makes the air supply distance up to 50m. Specific ESP design can be applied to various room types easily like L type / U type space. The air outlet can be set separately from the indoor unit so the air flow can be equally distributed even if the room is in irregular structure.

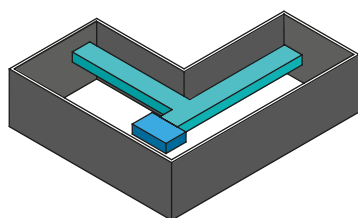
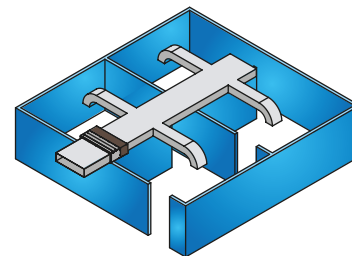

Room 1 : L Type

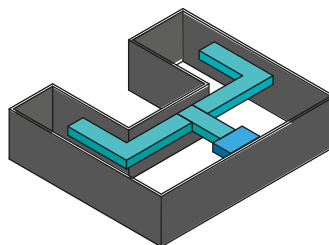

Room 2 : U Type

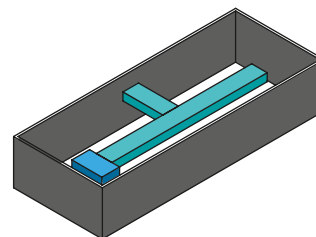

Room 3 : Narrow Type



Ducted Type – High Static Pressure

Model		WDH140IFM20EX	WDH175IFM20EX	WDH224IFM20EX	WDH280IFM20EX
Nominal Cooling Capacity	W	14000	17500	22400	28000
Nominal Heating Capacity	W	16000	19500	25000	31000
Rated Input Power	W	390	410	910	1020
Rated Input Current	A	1.85	1.95	2.08	2.25
External Static Pressure	Pa	50 (30/80)	50(30/80)	200	200
Sound Pressure Level	dB (A)	40/38/36	47/43/39	54	57
(High, Medium and Low)					
Air Volume	CMH	2200/1830/1520	3200/2900/2600	4100	4320
(High, Medium and Low)					
Liquid Pipe Connection Size	mm (in)	Ø9.52 (3/8")	Ø9.52(3/8")	Ø9.52(3/8")	Ø12.7 (4/8")
Gas Pipe Connection Size	mm (in)	Ø15.88 (5/8")	Ø15.88(5/8")	Ø22.23(7/8")	Ø22.23 (7/8")
Condensate Water Pipe Size	mm	Ø20.5	Ø20.5	Ø20.5	Ø20.5
Unit Size (W x D x H)	mm	1450 x 600 x 300	1450 x 600 x 300	1760 X 958 X 515	1760 X 958 X 515
Unit Weight	kg	48	48	131	133
Power Supply		220V~/50Hz	220V~/50Hz	380V/3N~/50Hz	380V/3N~/50Hz

Notes:

- Cooling Capacity:** Indoor temperature 27°C DB/19°C WB; Outdoor temperature: 35°C DB/ 24°C WB.
- Heating Capacity:** Indoor temperature 20°C DB; Outdoor temperature: 7°C DB/ 6°C WB.
- We can guarantee the operation only within 130% combination. If you want to connect more than 130% combination, please contact us and discuss the requirement.
- Anechoic chamber conversion value, measured in test room. During actual operation these values are somewhat higher as a result of ambient condition.
- The above designs and specifications are subject to change without prior notice. For final specifications please refer to technical specification provided by sales representative.
- Sound values are measured in a semi-anechoic room, at a position 1m in front of the unit and 1.3m above the floor.
- Choosing fuse or breaker according to MFA and electrical wiring according to MCA.
- The above data may be changed without notice for future improvement in quality and performance.

Outdoor Unit

Capacity	8 HP (6.4 TR) to 28 HP (22.4 TR)	30 HP (24 TR) to 56 HP (44.8 TR)	58 HP (46.4 TR) to 84 HP (67.2 TR)
Modular Outdoor Unit	 Single Module	 Double Module	 Triple Module

Nomenclature



Outdoor Units Line-up

Appearance	Capacity											
	8 HP	10 HP	12 HP	14 HP	16 HP	18 HP	20 HP	22 HP	24 HP	26 HP	28 HP	
Single Module	8 HP	*										
	10 HP		*									
	12 HP			*								
	14 HP				*							
	16 HP					*						
	18 HP						*					
	20 HP							*				
	22 HP								*			
	24 HP									*		
Double Module	26 HP									*		
	28 HP										*	
	30 HP			*								*
	32 HP				*							*
	34 HP			*								*
	36 HP								*			*
	38 HP		*									*
	40 HP			*								*
	42 HP				*							*
	44 HP					*						*
	46 HP						*					*
Triple Module	48 HP						*					*
	50 HP							*				*
	52 HP								*			*
	54 HP									*		*
	56 HP										*	**
	58 HP			*								*
	60 HP				*							*
	62 HP			*					*			*
	64 HP									*		*
	66 HP		*									**
	68 HP			*								**
	70 HP				*							**
	72 HP					*						**
	74 HP						*					**
	76 HP							*				**
78 HP								*			**	
80 HP									*		**	
82 HP										*	**	
84 HP											**	

Outdoor Technical Specification

Model		WDC80IFM20E3	WDC100IFM20E3	WDC120IFM20E3	WDC140IFM20E3	WDC160IFM20E3	WDC180IFM20E3
Nominal Cooling Capacity	KW	25.2	28	33.5	40	45	50.4
Nominal Heating Capacity	KW	28	31.5	37.5	45	50.6	56.5
Nominal Cooling Power	KW	6.3	7.35	9.39	10.98	12.75	14.83
Nominal Heating Power	KW	6.39	7.6	9.87	11.81	13.41	15.41
EER/COP		4/4.38	3.8/4.14	3.56/3.8	3.64/3.8	3.52/3.77	3.4/3.66
Maximum Operating Current	A	26.4	26.4	26.4	29.6	37.7	37.7
Power Supply		380V/3N/50Hz			380V/3N/50Hz		
Air Volume	CMH	9700	10600	10600	14000	14700	14700
Sound Pressure Level	dB(A)	54	58	58	60	60	61
Unit Size in mm	width	950	950	950	1340	1340	1340
	Depth	780	780	780	780	780	780
	Height	1650	1650	1650	1650	1650	1650
Liquid Pipe Connection Size	mm(in)	9.52(3/8")	12.7(1/2")		12.7(1/2")		
Gas Pipe Connection Size	mm(in)	22.23(7/8")			28.6(1-1/8")		
Operating Temperature Range		Cooling: -15~53°C; Heating: -25~28°C			Cooling: -15~53°C; Heating: -25~28°C		
Refrigerant		R410A			R410A		
Unit Weight	kg	218	219	220	259	307	323

Model		WDC200IFM20E3	WDC220IFM20E3	WDC240IFM20E3	WDC260IFM20E3	WDC280IFM20E3
Nominal Cooling Capacity	KW	56	61.5	68	73	78.5
Nominal Heating Capacity	KW	63	69	75	81.5	87.5
Nominal Cooling Power	KW	17.65	20.45	19.95	21.95	25.2
Nominal Heating Power	KW	17.04	19.72	20.49	23.32	26.2
EER/COP		3.17/3.69	3/3.49	3.4/3.66	3.32/3.49	3.11/3.33
Maximum Operating Current	A	51.8	51.8	52.4	57	57
Power Supply		380V/3N/50Hz			380V/3N/50Hz	
Air Volume	CMH	16500	16500	22000	22000	22000
Sound Pressure Level	dB(A)	62	62	62	62	63
Unit Size in mm	width	1340	1340	1680	1680	1680
	Depth	780	780	780	780	780
	Height	1650	1650	1650	1650	1650
Liquid Pipe Connection Size	mm(in)	15.88(5/8")		15.88(5/8")	19.05(3/4")	
Gas Pipe Connection Size	mm(in)	28.6(1-1/8")		28.6(1-1/8")	34.9(1-3/8")	
Operating Temperature Range		Cooling: -15~53°C; Heating: -25~28°C		Cooling: -15~53°C; Heating: -25~28°C		
Refrigerant		R410A			R410A	
Unit Weight	kg	368	369	445	457	457

Notes:

- Cooling Capacity:** Indoor temperature 27°C DB/19°C WB; Outdoor temperature: 35°C DB/ 24°C WB.
- Heating Capacity:** Indoor temperature 20°C DB; Outdoor temperature: 7°C DB/ 6°C WB.
- We can guarantee the operation only within 130% combination. If you want to connect more than 130% combination, please contact us and discuss the requirement.
- Anechoic chamber conversion value, measured in test room. During actual operation these values are somewhat higher as a result of ambient condition.
- The above designs and specifications are subject to change without prior notice. For final specifications please refer to technical specification provided by sales representative.
- Sound values are measured in a semi-anechoic room, at a position 1m in front of the unit and 1.3m above the floor.
- Choosing fuse or breaker according to MFA and electrical wiring according to MCA.
- The above data may be changed without notice for future improvement in quality and performance.

Outdoor Unit Type		WDC300IFM20E3	WDC320IFM20E3	WDC340IFM20E3	WDC360IFM20E3	WDC380IFM20E3	WDC400IFM20E3
Recommended Combination	HP	18+12	18+14	22+12	18+18	28+10	28+12
Nominal Cooling Capacity	KW	83.9	90.4	95.0	100.8	106.5	112.0
Nominal Heating Capacity	KW	94.0	101.5	106.5	113.0	119.0	125.0
Nominal Cooling Power	KW	24.2	25.8	29.8	29.7	32.6	34.6
Nominal Heating Power	KW	25.3	27.2	29.6	30.8	33.8	36.1
Maximum Operating Current	A	64.1	67.3	78.2	75.4	83.4	83.4
Power Supply		380V/3N/50Hz					
Air Volume	m ³ /h	25300	28700	27100	29400	32600	32600
Noise	dB(A)	63	64	64	64	64	64
Unit Size in mm	width	1340+950	1340+1340	1340+950	1340+1340	1680+950	1680+950
	Depth	780.0	780.0	780.0	780.0	780.0	780.0
	Height	1650.0	1650.0	1650.0	1650.0	1650.0	1650.0
Liquid Pipe Connection Size	mm(in)	19.05 (3/4")					
Gas Pipe Connection Size	mm(in)	28.6(1-1/8")			38.1(1-1/2")		
Operating Temperature Range		Cooling: -15~53°C; Heating: -25~28°C					
Refrigerants		R410A					
Unit Weight	kg	543	582	589	646	676	677

Outdoor Unit Type		WDC420IFM20E3	WDC440IFM20E3	WDC460IFM20E3	WDC480IFM20E3	WDC500IFM20E3	WDC520IFM20E3
Recommended Combination	HP	28+14	28+16	28+18	28+20	28+22	28+24
Nominal Cooling Capacity	KW	118.5	123.5	128.09	134.5	140.0	146.5
Nominal Heating Capacity	KW	132.5	138.1	144.0	150.5	156.5	162.5
Nominal Cooling Power	KW	36.2	38.0	40.0	42.9	45.7	45.2
Nominal Heating Power	KW	38.0	39.6	41.6	43.2	45.9	46.7
Maximum Operating Current	A	86.6	94.7	94.7	108.8	108.8	109.4
Power Supply		380V/3N/50Hz					
Air Volume	m ³ /h	36000	36700	36700	38500	38500	44000
Noise	dB(A)	65	65	65	66	66	66
Unit Size in mm	width	1680+1340	1680+1340	1680+1340	1680+1340	1680+1340	1680+1680
	Depth	780	780	780	780	780	780
	Height	1650	1650	1650	1650	1650	1650
Liquid Pipe Connection Size	mm(in)	19.05 (3/4")					
Gas Pipe Connection Size	mm(in)	38.1(1-1/2")					
Operating Temperature Range		Cooling: -15~53°C; Heating: -25~28°C					
Refrigerants		R410A					
Unit Weight	kg	716	764	780	825	826	902

Notes:

- Cooling Capacity:** Indoor temperature 27°C DB/19°C WB; Outdoor temperature: 35°C DB/ 24°C WB.
- Heating Capacity:** Indoor temperature 20°C DB; Outdoor temperature: 7°C DB/ 6°C WB.
- We can guarantee the operation only within 130% combination. If you want to connect more than 130% combination, please contact us and discuss the requirement.
- Anechoic chamber conversion value, measured in test room. During actual operation these values are somewhat higher as a result of ambient condition.
- The above designs and specifications are subject to change without prior notice. For final specifications please refer to technical specification provided by sales representative.
- Sound values are measured in a semi-anechoic room, at a position 1m in front of the unit and 1.3m above the floor.
- Choosing fuse or breaker according to MFA and electrical wiring according to MCA.
- The above data may be changed without notice for future improvement on quality and performance.

OUR HVAC IMPLEMENTED PROJECTS



HVAC Project List

SL	Projects	Location	Project Type	Capacity (TR)
1	Saif Plastic Ind. Ltd	Tongi, Gazipur	Chiller	20
2	Bashundhara Oil and Gas	Keraniganj, Dhaka	VRF	299.7
3	Isckon Mondir	Shamibag, Dhaka	VRF	116.7
4	Sun Yad Packaging	Tongi, Gazipur	VRF	25
5	UPS (Air Alliance)	Tongi, Gazipur	VRF	54
6	DW Navy Ctg	Chattogram	Precision AC	38
7	Sun Yad Packaging	Tongi, Gazipur	Chiller	37
8	MES (Navy)	Chattogram	VRF	124.9
9	Askan Development Ltd.	Jatrabari, Dhaka	VRF	700
10	Astha Super Shop	Shyamoli, Dhaka	VRF	35
11	Police Super Shop	Naogaon	VRF	57
12	PHP Float Glass	Chattogram	VRF	73
13	H.H. Mart	Savar	VRF	57
14	Dewan Villa	Chandra, Gazipur	VRF	57
15	Knit Asia	Joydebpur, Gazipur	VRF	57
16	Bangladesh Machine Tools Factory	Joydebpur, Gazipur	VRF	25.6
17	Knit Asia	Joydebpur, Gazipur	VRF	19
18	Nakshi Tower	Feni	VRF	307
19	Accord Trade & Technology	Joydebpur, Gazipur	VRF	17.6
20	Garden Resort	Tangail	VRF	38
21	TBN BD LTD	Shyamoli, Dhaka	VRF	24.2
22	Army Pharma	Joydebpur, Gazipur	Chiller, Clean Room	120
23	Redmin Industries Ltd	Badda, Dhaka	VRF	57.6
24	SQ Station	Valuka, Mymensingh	VRF	62
25	Jahura Akram Mem. Hospital	Pirojpur	VRF	140
26	Microbiology Lab	Joydebpur, Gazipur	Chiller	8.9
27	Fly Fair	Bashundhara, Dhaka	VRF	41.4
28	Swarga Chaya	Bashundhara, Dhaka	VRF	19.3
29	Caritus Bangladesh	Rajarbag, Dhaka	VRF	175
30	Kalmegh Club House	Gazipur	VRF	172.8
31	Central Workshop Dhaka Cantonment	Mirpur, Dhaka	Precision AC	10
32	Armed Force Institute of Pathology	Mirpur, Dhaka	Chiller	1200
33	Police Trust Industrial Products	Hatirjheel, Dhaka	Precision AC	10
34	Livens Sweatex Ltd	Savar, Dhaka	VRF	19.2
35	Akij Food & Beverage Ltd	Manikganj	VRF	35
36	Beximco Engineering Ltd	Dohar, Dhaka	VRF	161.6
37	United Landport Teknaf Ltd	Teknaf, Cox Bazar	VRF	54.4
38	One Direction	Bashundhara, Dhaka	VRF	115.2
39	Total Food	Khulna	VRF	59.1
40	Ramu Cantonment	Cox's Bazar	VRF	76
41	Aman Garments	Savar, Dhaka	VRF	19.2
42	Redmin Industries Ltd	Gazipur	Chiller	42
43	Ramu Cantonment	Cox's Bazar	VRF	64
44	Army Artillery Center-Halishahar	Chattogram	Roof Top Package	130
45	Bangladesh Bank	Motijheel, Dhaka	Chiller	650
46	Remark HB Ltd	Gazipur	Chiller	247.2
47	Beximco Engineering Ltd	Dohar, Dhaka	VRF	25.6
48	JM Fabrics Ltd	Joydebpur, Dhaka	VRF	60.6
49	Shajinaz Exim Pack Ltd	Chattogram	VRF	96.8
50	S&J Construction	Joydebpur, Dhaka	Chiller Local Work	NA
51	CA Knitwear Ltd	Savar, Dhaka	VRF	76.8
52	Utshab Super Market	Chattogram	VRF	96
53	Medix Hospital	Dhanmondi, Dhaka	VRF	19.2
54	Armed Force Institute of Pathology	Mirpur, Dhaka	Cold Room, Ventilation	

HVAC Project List

SL	Projects	Location	Project Type	Capacity (TR)
55	United Tank Terminal Limited	Anwara, Chattogram	VRF	38.4
56	Remark HB Ltd	Gazipur	VRF	36.7
57	Snowtex	Mirpur, Dhaka	VRF	89.6
58	NAZ Bangladesh Ltd	Baridhara, Dhaka	VRF	48
59	Green BD Polytechnic	Chapainawabganj	VRF	12.8
60	System Properties Ltd	Chattogram	VRF	230.4
61	Ocean Sweater Ltd	Joydevpur, Dhaka	VRF	8
62	Shajinaz Hospital	Chattogram	VRF	116.8
63	Dana Sweater Industries Limited	Savar, Dhaka	VRF	60.8
64	Ten Square Office (Daffodil University)	Ashulia, Dhaka	VRF	19.2
65	United Landport Teknaf Ltd	Teknaf, Cox Bazar	VRF	16
66	Knit Asia Ltd	Joydevpur, Dhaka	VRF	16
67	Remi Holdings Ltd	Narayanganj, Dhaka	VRF	35.2
68	Ocean Sweater Ind Pvt Ltd	Joydevpur, Dhaka	VRF	70.6
69	Barhatta Enterprise	Gulshan, Dhaka	VRF	16
70	Daffodil University Data Center	Ashulia, Dhaka	VRF	16
71	Independent University Bangladesh	Bashundhara, Dhaka	VRF	32
72	Square Informatix	Gazipur	VRF	19.2
73	Shwapno Super Shop	Khulna	VRF	19.2
74	Coats Bangladesh Ltd	Gazipur	VRF	16
75	Remark HB Ltd	Gazipur	Chiller	20
76	CA Knitwear Ltd	Savar, Dhaka	VRF	19.2
77	Knit Asia Ltd	Joydevpur, Dhaka	VRF	19.2
78	Sara LifeStyle	Feni	VRF	38.4
79	Abahani Sports Complex	Dhanmondi, Dhaka	VRF	487
80	Ocean Sweater Ind Pvt Ltd	Joydevpur, Dhaka	VRF	8
81	Unido Pharma	Narsingdi	VRF	8
82	Shwapno Super Shop	Agargaon, Dhaka	VRF	35
83	Beximco Holdings Ltd	Tejgaon, Dhaka	VRF	212
84	Beximco Holdings Ltd	Tejgaon, Dhaka	VRF	8
85	Karnaphuli Tunnel	Chattogram	VRF & LCAC	595
86	Shajinaz Hospital	Chattogram	VRF	76.8
87	BITAC	Tejgaon, Dhaka	VRF	192
88	Neuclear Powerplant	Pabna	VRF	35.2
89	Shajinaz Hospital	Chattogram	VRF	51.2
90	Beximco Engineering Ltd	Dohar, Dhaka	Local Works	-
91	Apartment of Tanna Mam	Bashundhara, Dhaka	VRF	35.2
92	City Interdec & Construction	Sadarghat, Dhaka	VRF	16
93	Bangabandhu Bhaban	Sadarghat, Dhaka	VRF	144
94	Remark HB Ltd	Gazipur	VRF	25.4
95	Palongki Restaurant	Cox's Bazar	VRF	32
96	Mount Adora Hospital	Sylhet	VRF	57.6
97	Sara LifeStyle	Barishal	VRF	32

The Masterpiece from HVAC Experts

IFM SERIES



Features

- Centralized Monitoring System
- Energy Saving Technology : Adopt “ Smooth Driving Control ”
- Enhanced Vapor Injection (EVI) Technology
- DC Drive Inverter Scroll Compressor
- High Comprehensive Efficiency with IPLV
- High Energy Efficiency Ratio (EER)
- Two Stage Sub-cooling
- Smart Oil Management Technology
- Refrigerant PCB Cooling Technology
- Long Piping Length
- Auto Dust Removal Technology
- Maximum Combination Ratio up to 200%



Subject to change without any prior notice

Headquarters : Chandra, Kaliakoir, Gazipur, Bangladesh.

Corporate Office : Block: I, Road: Sabrina Sobhan 5th Avenue, Bashundhara, Vatara Dhaka-1229, Bangladesh, Tel : +8809606-555555, Cell : +8801678-863476
E-mail : info@waltonbd.com; sales-vrft24@waltonbd.com

For Details: 16267
Toll Free: 08000016267

waltonbd.com

